



Why Ahmedabad University?

A PRIVATE UNIVERSITY WITH A PUBLIC ETHOS

Ahmedabad University is a private, non-profit institution established in 2009 by 89-year old Ahmedabad Education Society (AES). Located in the heart of one of India's most dynamic, entrepreneurial, and fast-growing cities, the University has top facilities and a diverse range of programmes with emphasis on interdisciplinarity. The graduate programmes leading to MTech and PhD degrees are research based and connected with related industries. All faculty are actively engaged in research.

We are re-imagining the classroom beyond walls and with rigorous, broad-based education that connects with relevant industries. Besides Engineering, the University has Schools of Arts and Sciences, Management, and Public Health. The University strongly supports multi-disciplinary learning and research, and experiential learning.

RIGOROUS

Ahmedabad University is strongly research oriented and all faculty are actively engaged in research including collaborative interdisciplinary research. Students are encouraged and supported to pursue their own research.

HANDS-ON

Students experience hands-on learning to engage with real-life challenges which build skills for a lifetime. The University has extensive laboratories, facilities, equipment and computational tools and resources.

Apply Now!

ELIGIBILITY

You can pursue this MTech programme if you have a BTech degree in any of these disciplines: Mechanical, Aerospace, Chemical, Metallurgy, Material Science, Civil, Textile, Naval Architecture, Marine, Mining, Production & Industrial, Engineering Sciences or Agricultural engineering. Students expecting to complete BTech degree requirements by Summer 2024 can also apply. A GATE score is optional.

FINANCIAL AID

A limited number of assistantships are available where the student will have to undertake teaching responsibilities under the supervision of a faculty member.

SPONSORED CANDIDATES

Industries willing to sponsor their engineers for this programme can contact Dean, School of Engineering and Applied Science. Engineers in employment wishing to pursue MTech in composites may apply with concurrence of their organisation.

CAMPUS LIFE

The modern, eco-friendly, and fully networked campus comprising classrooms, laboratories, a central library, and e-learning applications provides an enriching learning experience. Extensive sports facilities, cafes, spaces for co-curricular activities, and wellness centre, among other facilities, contribute to the students' overall wellbeing.

HOUSING

Graduate student accommodation and food facilities are available on campus. Regular shuttle services are available for intra-campus commute.





For more information and application form, scan the QR Code below.

Visit | www.ahduni.edu.in

Office of Graduate Admissions

Ahmedabad University, Navrangpura, Ahmedabad 380009

mtech.admissions@ahduni.edu.in
+91 8799189868, (079) 61911126

-  ahduni.edu.in/seas
-  [AhmedabadUniversity](https://www.facebook.com/AhmedabadUniversity)
-  [ahmedabad_university](https://www.instagram.com/ahmedabad_university)
-  [ahduni](https://twitter.com/ahduni)



Ahmedabad
University

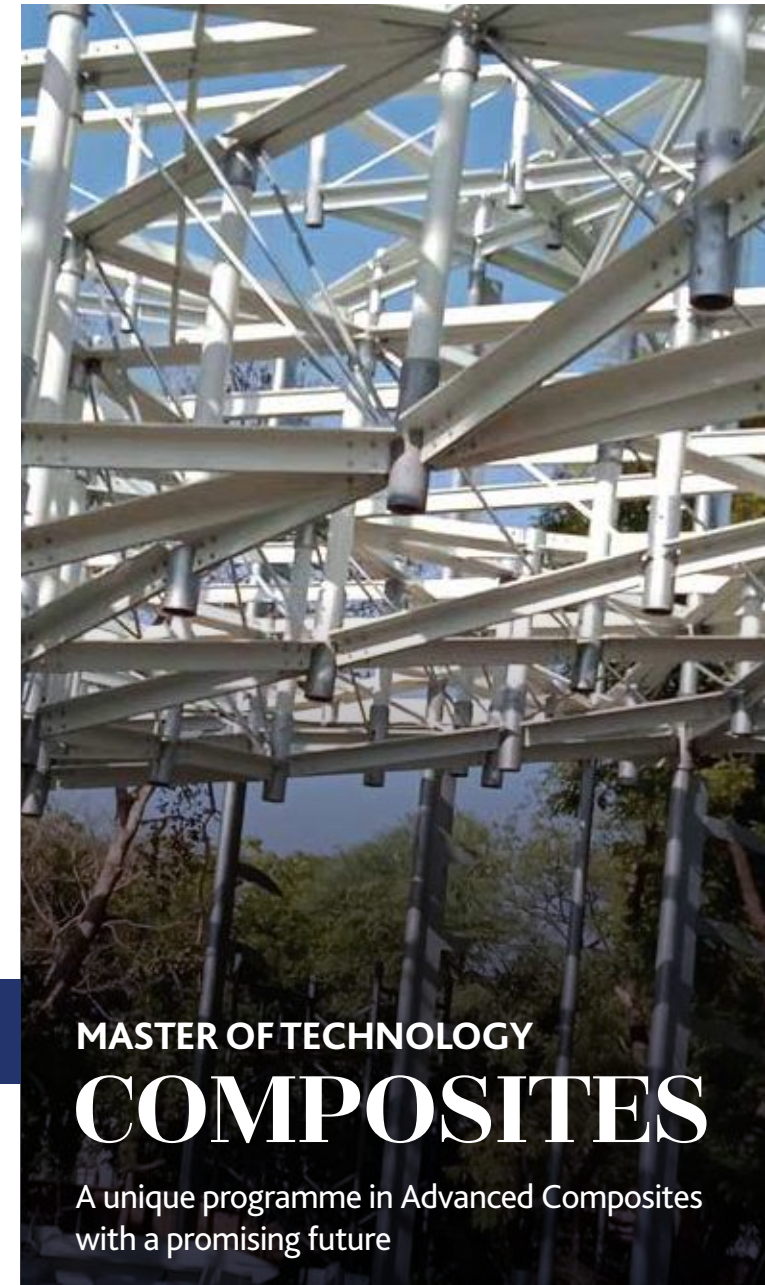

MASTER OF TECHNOLOGY COMPOSITES

A unique programme in Advanced Composites
with a promising future

SCHOOL OF ENGINEERING AND APPLIED SCIENCE

Mastering Composites

Emerging economies like India are focusing on manufacturing indigenous engineering products, with aerospace, defense, and urban mobility being the key sectors. This has increased the use of advanced lightweight composites for weight savings, improving fuel economy, payload, quality, and service life- a trend expected to grow. This calls for highly skilled engineers with proficiency in designing, developing, testing, and manufacturing parts and assemblies involving advanced composite materials.

The School of Engineering and Applied Science at Ahmedabad University will offer a new Master of Technology programme specialising in Composites from 2024-2025. This programme is being offered in partnership with Ahmedabad Textile Industry's Research Association (ATIRA) who have pioneered design, development and testing of composites. Aligned with industry needs, the programme will provide comprehensive knowledge about composites design and materials, tooling, testing, manufacturing supply chain, quality assurance, and industry-related professional practices.

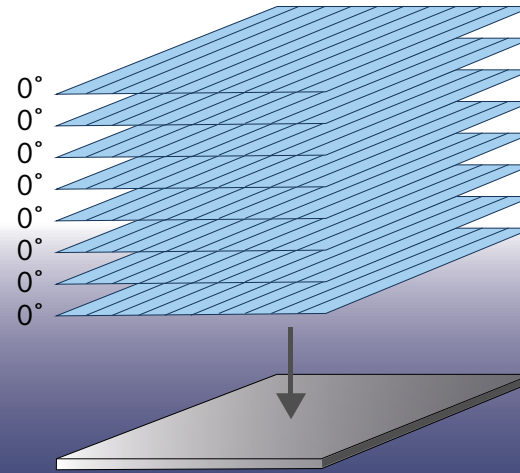

Unidirectional

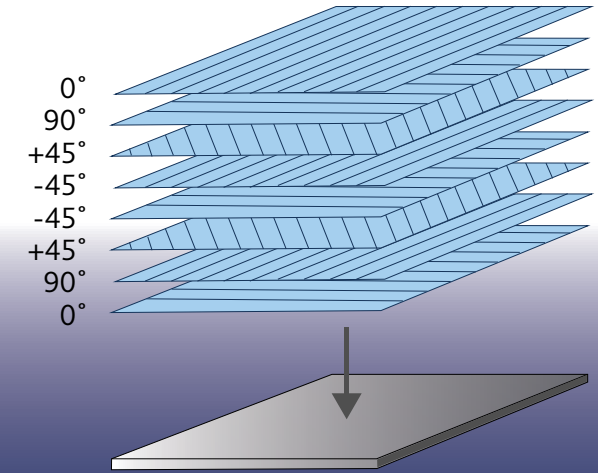

Cross-ply quasi-isotropic

Curriculum Structure

The programme will start with strengthening the fundamentals and provide a strong core in advanced mechanics, numerical methods, materials, manufacturing processes, and design methods in composites. Students will be continuously exposed to state-of-the-art CAD/CAE tools and best-in-class industry practices.

FUNDAMENTALS

- Mathematics for Composites
- Mechanics of Composites
- Basics of Composites
- Communication Skills

DESIGN SKILLS

- Analysis of Composites
- CAD of Composites
- FEA and CAE of Composites

MANUFACTURING

- Autoclave and Out-of-Autoclave Processes
- Tool Design and Manufacturing
- Additive Manufacturing
- Quality Inspection and Management

INDUSTRY PRACTICES

- Testing and Design Validation
- Q&M and Inspection
- Perspectives on Composites

INDUSTRY EXPOSURE

- Design Processes for Composites
- Engineering and Manufacturing Processes
- Tooling for Composites

REAL WORLD APPLICATION

- Thesis at Industry

Each student will work on a thesis which will be on an industry linked project.

Careers in Composites

Graduates' Employability:

The MTech in Composites provides knowledge with perfect blend of state-of-the-art knowledge, design aspects, modern manufacturing practices, and industry-based projects which will enable the graduates to work in industry or take up research.

Industry Benefits:

Composites related industries will benefit by deploying job ready graduates be able to contribute to industry goals right from the first day. Industries can sponsor specific projects on topics of interest in their line of work.

Research & Patents:

This specialised programme in Composites will also enable:

- Composites specific research work leading to PhD degree
- Generating IPR by way of patents, design registration
- Joint work on industry projects and problem solving
- Publishing and presenting technical research work in national and international journals and conferences.

Career Pathways

Below is a list of companies that work with Composites:

- Hindustan Aeronautics Ltd (HAL) ▪ Boeing ▪ Maini Aerospace
- National Aerospace Laboratories (NAL) ▪ Infosys ▪ Kineco Limited ▪
- Arvind Advanced Materials ▪ Tata Motors ▪ Mahindra Defence ▪
- HCL Technologies ▪ Aeronautical Development Agency (ADA) ▪
- Defence Research and Development Organization (DRDO) ▪
- Indian Space Research Organization (ISRO) ▪ Airbus ▪
- Aeronautical Development Establishment (ADE) ▪ L&T ▪
- Adani Defence Systems and Technologies Limited ▪
- Absolute Composites Pvt Ltd ▪ Tata Advanced Systems Ltd. (TASL)

